

REELSTRONG®

UTILITY FLEET

MRST3-RC-84-60 POWERLOCK™ REEL / CARGO TRAILER SPECS

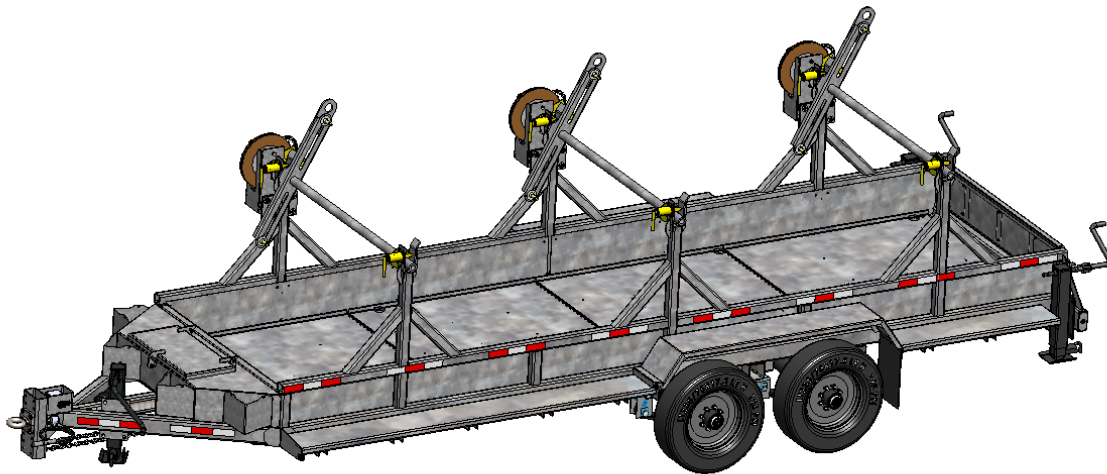

EXCLUSIVE STANDARD ADDED VALUE:

- POWERLOCK™ Technology Provides Industry Leading Safety, Ease of Use, Low Maintenance and Durability.
 - SAFETY and Peace of Mind
 - No Pins, Cotters, or Lanyards that Secure the Reel Arbor (which is the most critical safety point).
 - Faster Reel Loading, Unloading, and Deployment Reduces Labor Costs and Fatigue on Workers.

BUILT FOR SAFETY. BUILT FOR SPEED. BUILT TO LAST.

CAPACITIES: 27,600 lbs. GVWR @ 15% Tongue Weight

AXLES: Tandem 12K lbs. Sprung

WHEELS: (4) 17.5 x 6.75 HC / 8 on 6.5 BC w/ 0.19 Inset

TIRES: (4) ST-235/75R17.5 LR-J Tires

BRAKES: 12.25" x 5.00" Electric w/ Safety Breakaway Kit

PAYLOAD: ALL FINAL PAYLOADS BASED ON CHOSEN MODEL AND OPTIONS

REEL / CARGO WEIGHT (PAYLOAD): 20,400 lbs. (6,800 lbs. per Reel)

REEL DIAMETER: (3) 84" Maximum

REEL WIDTH: 60" Maximum

REEL SHAFT DIAMETER: 2.50" Tube w/ Centering Collars

OVERALL LENGTH: 320" Approx.

OVERALL WIDTH: 102"

OVERALL WEIGHT: 7,200 lbs. Approx. (Actual Trailer Weight will Vary with Options & Finishes Chosen)

STANDARD FEATURES

- POWERLOCK™ Technology Provides Industry Leading Safety, Ease of Use, Low Maintenance and Durability.
- Oil Bath Hubs (Greaseable Option All)
- Electric Brakes
- Wheel Chock Holders

STANDARD TRAILER BODY

- Heavy Duty 5" X 3" X 1/4"
- 6-Position Adjustable Hitch
- 3/8" X 36" GR70 Yellow Zinc Safety Chains with Hooks
- 12,000 lbs. Static Front Jack w/ Spring Return
- Ground Lug: Copper Alloy Bolted to Frame
- Fenders: 1/8" Tread Plate
- Grip Strut Cat Walks
- Cargo Area: Approx. 66.5" Wide x 244.88" Long x 15" Tall
- Floor: 1/8" Steel Plate

STANDARD TRAILER BODY (cont.)

- A-frame: 5' Long

WIRING

- DOT / ICC Approved LED Lights and Conspicuity Reflective Tape
- FMVSS / CMVSS Standard 108 LED Lighting
- Sealed Beam, Rubber Mounted Stop, Turn, Tail and Marker Lights
- 100% Sealed Heat-Shrunked Wiring Connections w/ Full Loom
- Breakaway Kit with Absorbed Glass Mat (AGM) Battery

PAINT

- Biodegradable Pretreat Acid Cleaning (Superior to re-used sandblasting material that can impregnate metals with oil)
- Seams Caulked
- Rust Preventative 2-Part Epoxy Primer
- Standard Colors: Red, Black, White and CAT Yellow

OPTIONS

- 13 HP HONDA Engine Hydraulic Power Pack Comes STANDARD w/ ENGINE COVER, 15 Gallon Reservoir, Replaceable Oil Filter, Pressure Gauge and Solar Fade Resistant Plastic Control Placard. (Electric Start Optional)
- 10-Year Galvanized Structural Warranty (2-Year Painted)
- 3,300 or 4,800 ft/lbs Torque Hydraulic Take-up Retriever. (*Motor Spooled w/ Reel Brake ILO Cross-Over Relief Valve for Smooth Instant Reel Stoppage*)
- 2-7/16" Universal Adapter for Capstan and Power Reel Attachments
- 7 Inch General Purpose Capstan
- Collapsible Power Reel
- Rotating Arbor Ground
- Rewind Leveler
- 16" Bronze Alloy Ventilated Reel Brake w/ Ventilated Guard
- 16" Long 6-Bolt Hitch Extension (w/ 52" Safety Chains and Breakaway Cable Extension)
- 3" Lunette Eye
- Aluminum or Steel Toolbox
- 10K-HD / 15K / 20K Axles Available w/ Air Brakes
- Anti-Lock Brakes (ABS)
- Wiring Connections Soldered and Sealed w/ Heat Shrink Tubing
- Plug-and-Play Sealco Wiring Harness
- Wheel Chocks: Rubber or All Weather Galvanized Grip Strut
- Spare Tire and Mount
- Solar Charged Breakaway Kit
- Strobe Warning Lights
- All Stainless Steel Fasteners (1/2" and under)
- Hydraulic Front Jack

OPTIONS (cont.)

- Rear Underground Fairlead Roller Attachment (accommodates wooden plank rear gate)
- Truck-Lite Lighting
- Lug Nut Indicators

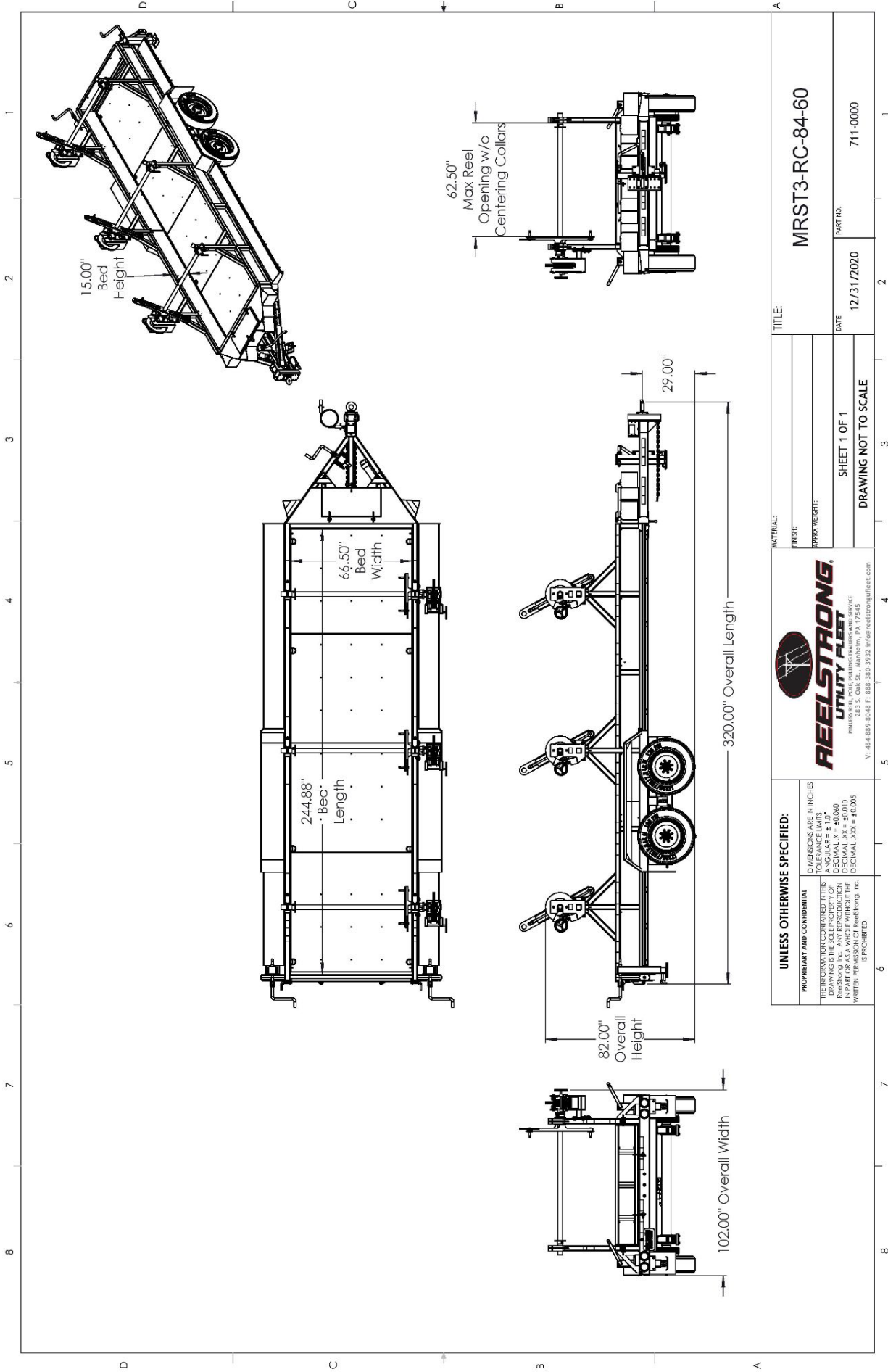

UNLESS OTHERWISE SPECIFIED:
 DIMENSIONS ARE IN INCHES
 TOLERANCE LIMITS
 FINISHES
 DRAWING IS THE SOLE PROPERTY OF REEELSTRONG UTILITY FLEET INC. IT IS TO BE USED ONLY FOR THE PART OR AS A WHOLE WITHOUT THE WRITTEN PERMISSION OF Reeelstrong Inc. IS PROHIBITED.



MATERIAL:
 FINISH:
 APPROX WEIGHT:
 SHEET 1 OF 1
 DRAWING NOT TO SCALE

TITLE: **MRST3-RC-84-60**
 DATE: 12/31/2020
 PART NO.: 711-0000